

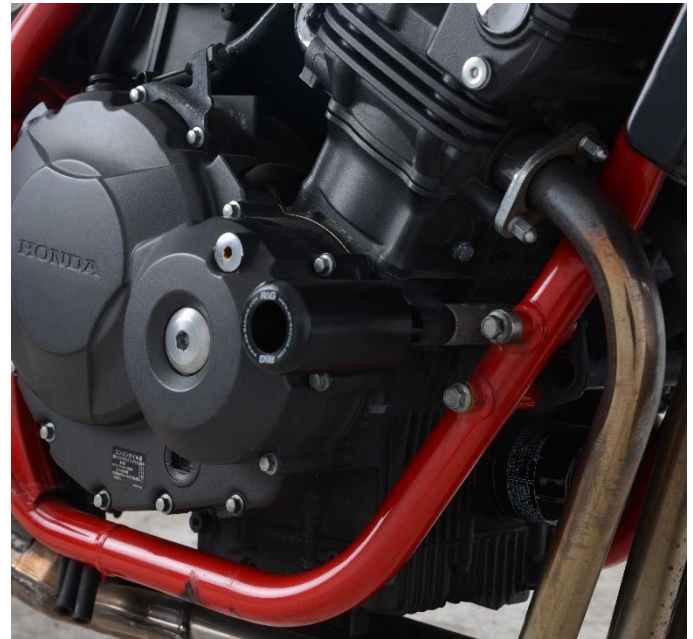

**FITTING INSTRUCTIONS FOR CP0468 CRASH PROTECTORS (ROUND)
FOR HONDA CB400SF 2008-**

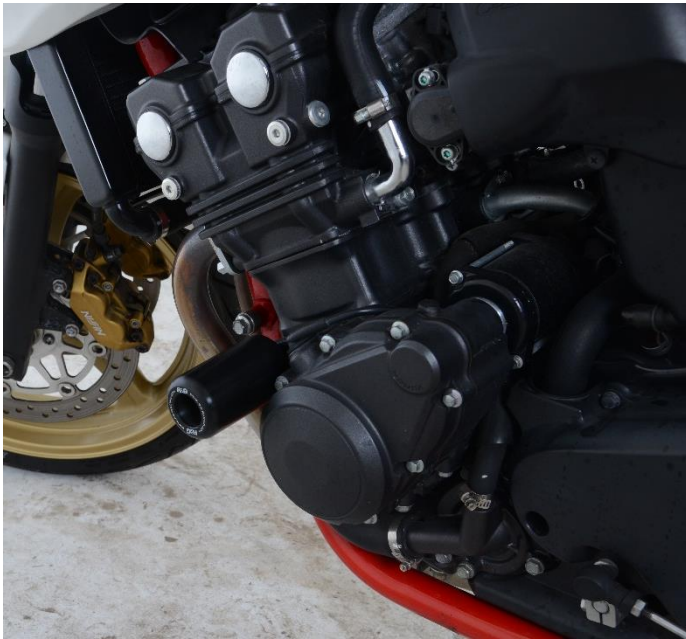

THIS KIT CONTAINS THE ITEMS PICTURED AND LABELLED IN THE FOLLOWING INSTRUCTIONS.

THE PARTS SHOWN MAY BE REPRESENTATIVE OR FOR CLARITY OF INSTRUCTIONS.

PLEASE NOTE THAT THE WAY THE KIT IS PACKED DOES NOT NECESSARILY REPRESENT THE WAY OF MOUNTING TO THE BIKE
IN THE EVENT WHERE KITS ARE PACKED WITH RUBBER WASHERS HOLDING THE COMPONENTS ONTO THE BOLT - THE RUBBER WASHERS SHOULD BE THROWN AWAY!

DO NOT PROCEED UNTIL YOU ARE SURE ALL PARTS ARE PRESENT

IF IN ANY DOUBT WHEN FITTING OUR PRODUCTS, CONSULT ONE OF OUR DEALERS OR HAVE FITTED BY A QUALIFIED TECHNICIAN.

**DIGITAL COPIES OF THESE INSTRUCTIONS ARE AVAILABLE TO DOWNLOAD FROM:
WWW.RG-RACING.COM**

R&G

Unit 1, Shelley's Lane, East Worldham, Alton, Hampshire, GU34 3AQ
Tel: +44 (0)1420 89007 Fax: +44 (0)1420 87301 www.rg-racing.com Email: info@rg-racing.com



<u>TOOLS REQUIRED</u>	<u>GENERAL TORQUE SETTINGS</u>
<ul style="list-style-type: none"> • SOCKET SET TO INCLUDE 14mm and 17mm SOCKET • 14mm SPANNER 	M4 BOLT = 8Nm M5 BOLT = 12Nm M6 BOLT = 15Nm M8 BOLT = 20Nm M10 BOLT = 40Nm M12 BOLT = 40Nm

LEGEND

<u>ITEM NO.</u>	<u>DESCRIPTION</u>	<u>QTY</u>
ITEM 1	B0005 10MM CRASH PROTECTOR	2
ITEM 2	S0727 SPACER (5mm)	1
ITEM 3	S0326 SPACER (23mm)	1
ITEM 4	M10 x 1.25 x 180mm HEX HEAD BOLT	2
ITEM 5	M10 x 19MM OD WASHER	2
ITEM 6	M10 NYLOC NUT	2
ITEM 7	SHAKE PROOF WASHERS	2

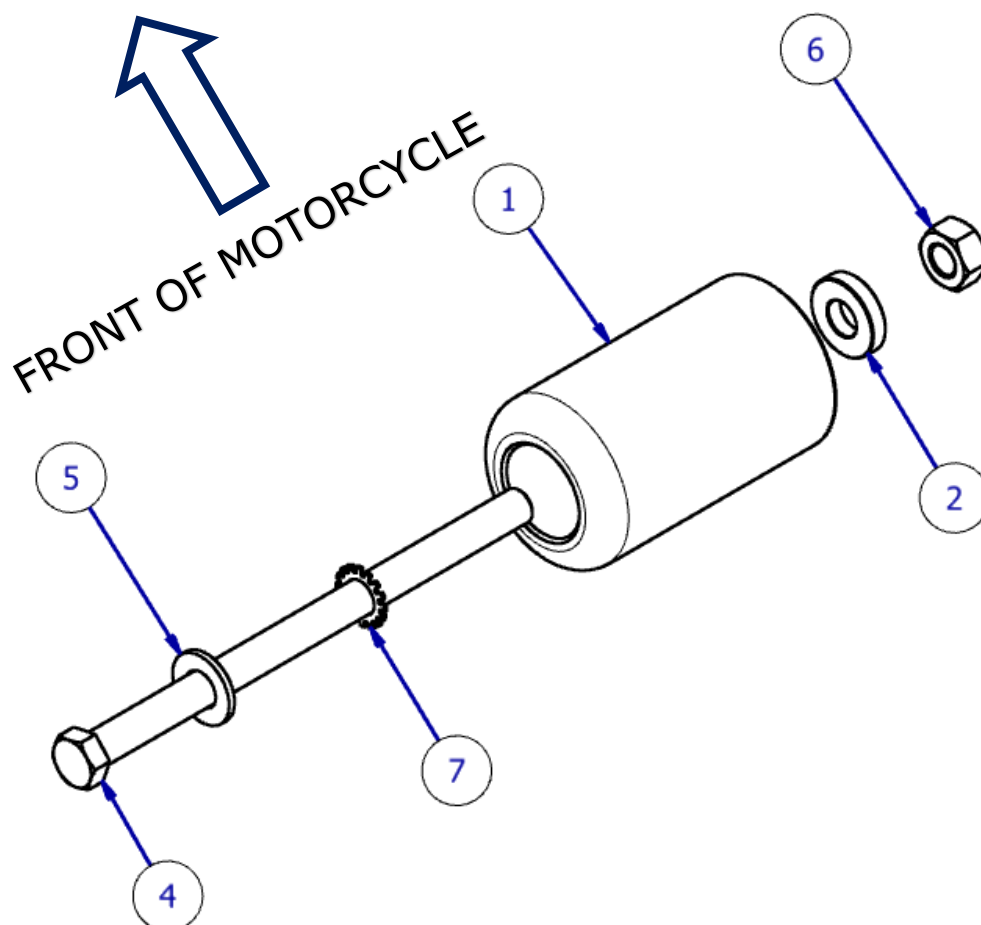

ASSEMBLY DIAGRAM 1 - LEFT HAND SIDE

R&G

Unit 1, Shelley's Lane, East Worldham, Alton, Hampshire, GU34 3AQ

Tel: +44 (0)1420 89007 Fax: +44 (0)1420 87301 www.rg-racing.com Email: info@rg-racing.com

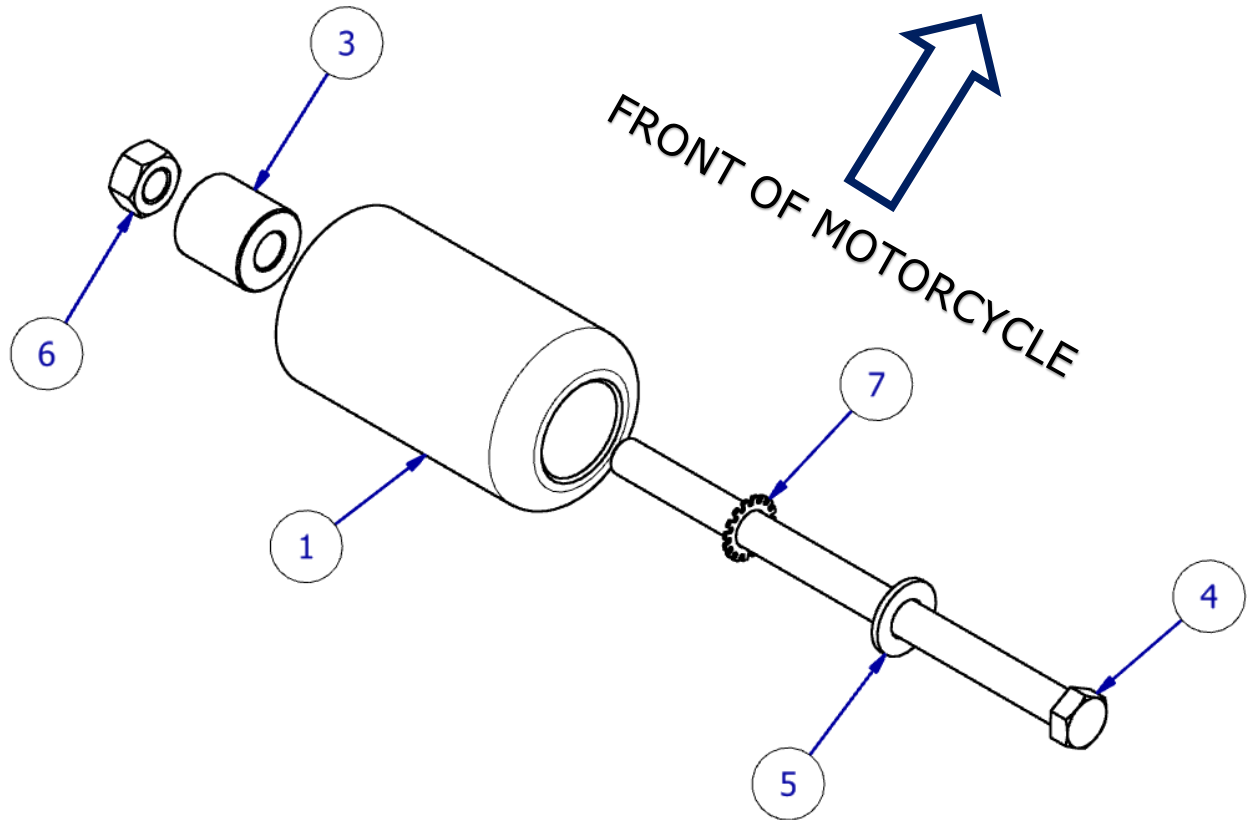

ASSEMBLY DIAGRAM 2 – RIGHT HAND SIDE

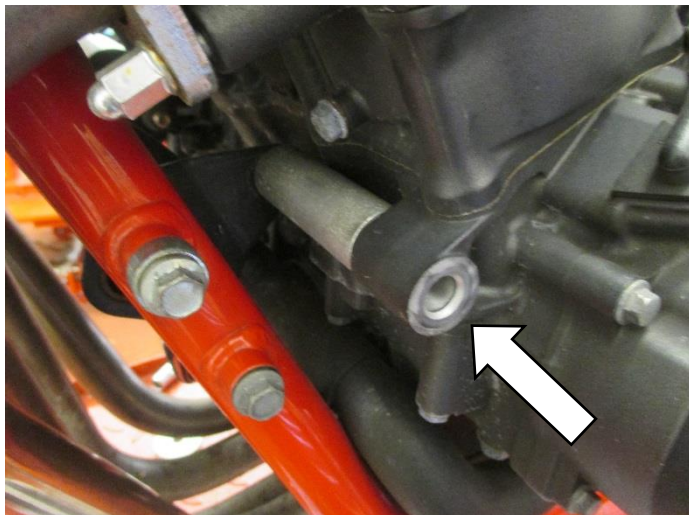

PICTURE 1

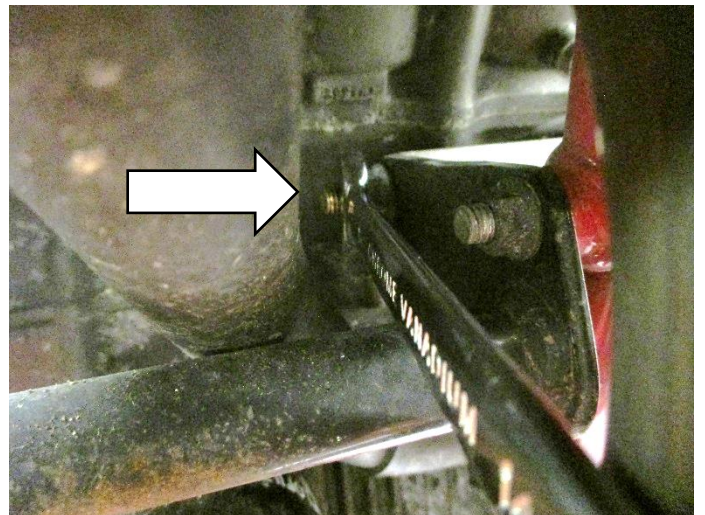

PICTURE 2

R&G

Unit 1, Shelley's Lane, East Worldham, Alton, Hampshire, GU34 3AQ

Tel: +44 (0)1420 89007 Fax: +44 (0)1420 87301 www.rg-racing.com Email: info@rg-racing.com



PICTURE 3



PICTURE 4

FITTING INSTRUCTIONS

Left Hand Side (as you sit on the bike)

- **Before fitting the R&G crash protectors, it is advised that a scissor jack is positioned underneath the bike at a suitable mounting point to support the weight of the engine during fitment. A small piece of wood should also be placed between the jack and the mounting point to help to spread the load. Do not remove more than one engine bolt at any time during the fitting to prevent the engine moving.**
- Remove the engine bolt on the left-hand side of the bike arrowed in **picture 1**. You will need to hold the rear nut on the back of the engine bolt with a 14mm spanner as shown in **picture 2** whilst unwinding the bolt.
- Ensure that the OEM spacer, arrowed in **picture 3**, between engine and frame mounting bracket stays in position during bolt removal.
- Assemble the LHS crash protector as shown in **Assembly Diagram 1** by sliding one M10 washer (item 5) followed by shake-proof washer (item 7) over the end of either M10 x 1.25 x 180mm bolt (item 4).
- Next slide one B0005 Crash Protector (item 1) over the bolt assembly followed by the smaller S0727 spacer (item 2). Your assembly should now resemble that in **picture 3**.
- Insert the assembly in place of the original engine bolt through the engine mount hole, OEM spacer and frame bracket so that the threads protrude through the frame bracket as in **picture 4**.
- Fix one M10 Nyloc nut (item 6) onto the exposed threads in place of the OEM nut using your 14mm spanner and 17mm to tighten the nut and bolt assembly to the recommended torque setting. Ensure that the threads of the bolt protrude through the plastic nut completely and the bobbin cannot spin.

R&G

Unit 1, Shelley's Lane, East Worldham, Alton, Hampshire, GU34 3AQ

Tel: +44 (0)1420 89007 Fax: +44 (0)1420 87301 www.rg-racing.com Email: info@rg-racing.com

**Right Hand Side (as you sit on the bike)**

- Moving to the right-hand side of the bike, repeat the previous steps, assembling the crash protector using the longer S0326 spacer (item 3) referring to **Assembly Diagram 2**
- Check both sides are secure, and the crash protectors cannot rotate freely before riding.
- Check tightness of each side regularly.

ISSUE 1 09/08/2019 (DM)

CONSUMER NOTICE

The catalogue description and any exhibition of samples are only broad indications of the Products and R&G may make design changes which do not diminish their performance or visual appeal and supplying them in such state shall conform to the order. The Buyer acknowledges no representation or warranty (other than as to title) has been given or will apply to the Products other than those in R&G's order or confirmation and the Buyer confirms it has chosen the Products as being of merchantable quality and suitable for its particular purposes. Where R&G fits the Products or undertakes other services it shall exercise reasonable skill and care and rectify any fault free of charge unless the workmanship has been disturbed. The Buyer is responsible for ensuring that the warranty on the motorcycle is not affected by the fitting of the Products. On return of any defective Products R&G shall at its option either supply a replacement or refund the purchase money but shall not be liable if the Products have been modified or used or maintained otherwise than in accordance with R&G's or manufacturer's instructions and good engineering practice or if the defect arises from accident or neglect. Other than identified above and subject to R&G not limiting its liability for causing death and personal injury, it shall not be liable for indirect or consequential loss and otherwise its liability shall be limited to the amounts paid by the Buyer for the Products or the fitting or service concerned. These terms do not affect the Buyer's statutory rights.

R&G RACING RETURNS POLICY (NON-FAULTY GOODS)

Returns must be pre-authorized (if not pre-authorized the return will be rejected). Goods may only be returned direct to us if they were purchased direct from us (customer must prove if necessary). Otherwise to be returned to original vendor. Goods must be in re-sellable condition, in the opinion of R&G Racing. All returns are subject to a 25% restocking and handling fee (25% of the gross value exc. P&P – at the prevailing price at time of purchase). The customer must pay any and all carriage charges. No returns of discontinued products, unless within 14 days of purchase. This policy does not affect your statutory rights and does not refer to faulty goods.

R&G

Unit 1, Shelley's Lane, East Worldham, Alton, Hampshire, GU34 3AQ

Tel: +44 (0)1420 89007 Fax: +44 (0)1420 87301 www.rg-racing.com Email: info@rg-racing.com



**NOTICE DE MONTAGE POUR CP0468 PROTECTIONS CRASH (RONDES)
POUR HONDA CB400SF 2008-**

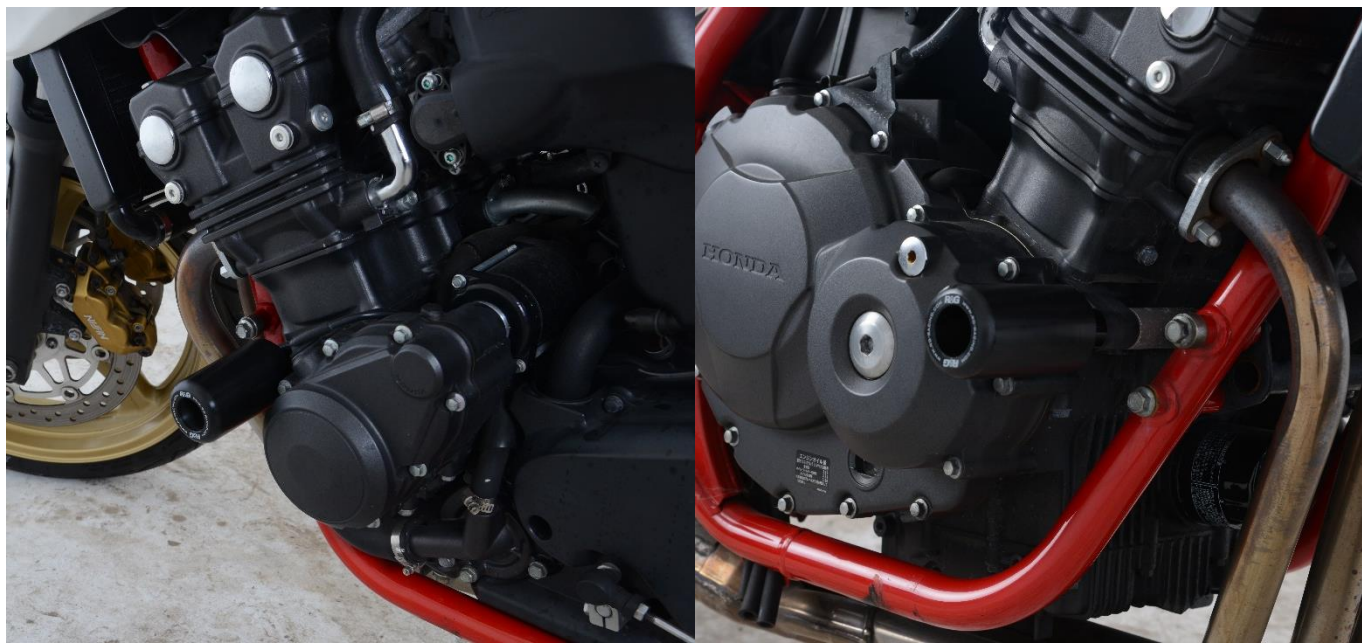

LE KIT CONTIENT LES ARTICLES EXPOSES CI-DESSOUS, VERIFIER QUE TOUTES LES PIECES SOIENT PRESENTES AVANT DE PROCEDER AU MONTAGE.

LES PARTIES PRESENTÉES PEUVENT ETRE UNIQUEMENT REPRESENTATIVES (POUR LA CLARTE DES INSTRUCTIONS UNIQUEMENT).

LA FAÇON DONT LE KIT EST EMBALLE NE CORRESPOND PAS FORCEMENT A LA FAÇON DE MONTER LES PIECES SUR LA MOTO.

NOTEZ QUE SI LES KITS SONT EMBALLES AVEC DES RONDELLES EN CAOUTCHOUC SERVANT A TENIR LES COMPOSANTS, CES RONDELLES DOIVENT ETRE JETTES !

NE PAS PROCEDER AU MONTAGE AVANT DE VOUS ETRES ASSURE QUE TOUTES LES PIECES SOIENT PRESENTES

EN CAS DE DOUTE LORS DU MONTAGE, CONSULTEZ UN DE NOS REVENDEURS, OU FAITES EFFECTUER LE MONTAGE PAR UN TECHNICIEN QUALIFIE.

**NOTICE DISPONIBLE AU TELECHARGEMENT SUR :
WWW.RG-RACING.COM**

R&G

Unit 1, Shelley's Lane, East Worldham, Alton, Hampshire, GU34 3AQ

Tel: +44 (0)1420 89007 Fax: +44 (0)1420 87301 www.rg-racing.com Email: info@rg-racing.com



OUTILS REQUIS	VALEURS DE SERRAGE
<ul style="list-style-type: none"> Clé à cliquet + douilles 14mm et 17mm Clé à molette 14mm 	M4 BOULON = 8Nm M5 BOULON = 12Nm M6 BOULON = 15Nm M8 BOULON = 20Nm M10 BOULON = 40Nm M12 BOULON = 40Nm

LEGENDE

ARTICLE NO.	DESCRIPTION	QTE
ARTICLE 1	B0005 10MM PROTECTION CRASH	2
ARTICLE 2	S0727 ENTRETOISE (5mm)	1
ARTICLE 3	S0326 ENTRETOISE (23mm)	1
ARTICLE 4	M10 x 1.25 x 180mm BOULON	2
ARTICLE 5	M10 x 19MM OD RONDELLE	2
ARTICLE 6	M10 ECROU	2
ARTICLE 7	RONDELLES ANTI VIBRATION	2

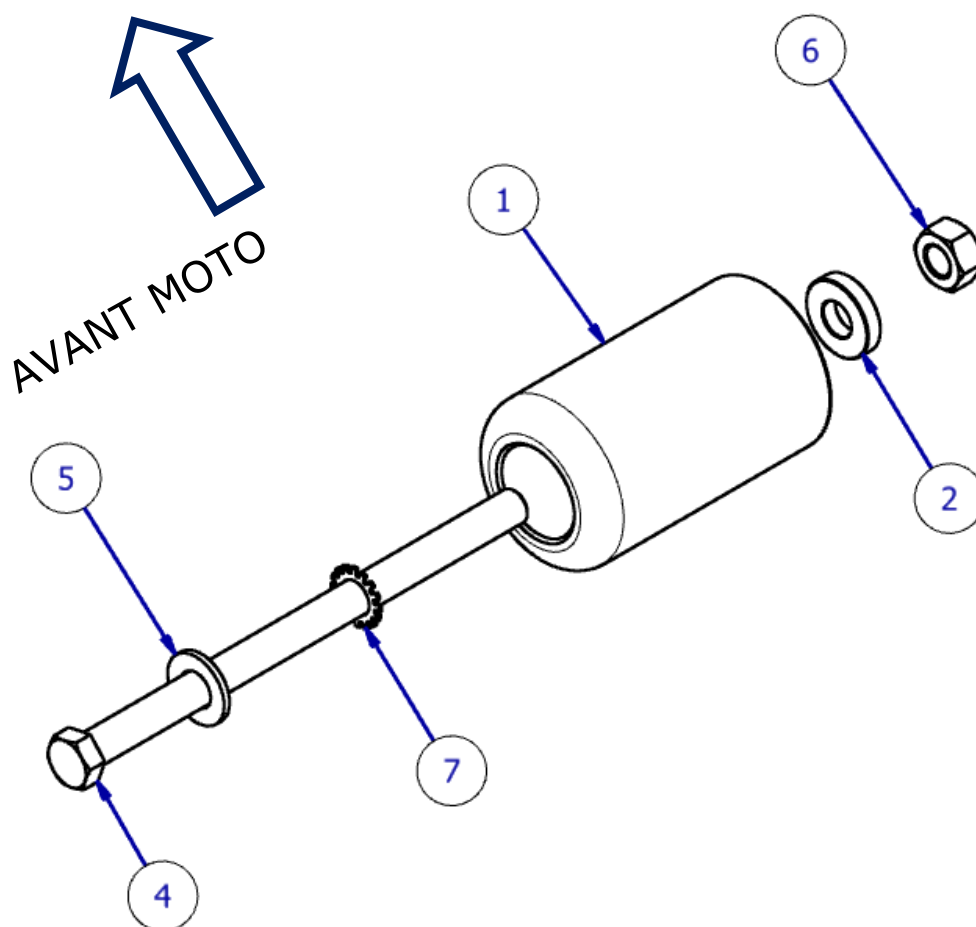

SCHEMA DE MONTAGE 1 – COTE GAUCHE

R&G

Unit 1, Shelley's Lane, East Worldham, Alton, Hampshire, GU34 3AQ

Tel: +44 (0)1420 89007 Fax: +44 (0)1420 87301 www.rg-racing.com Email: info@rg-racing.com

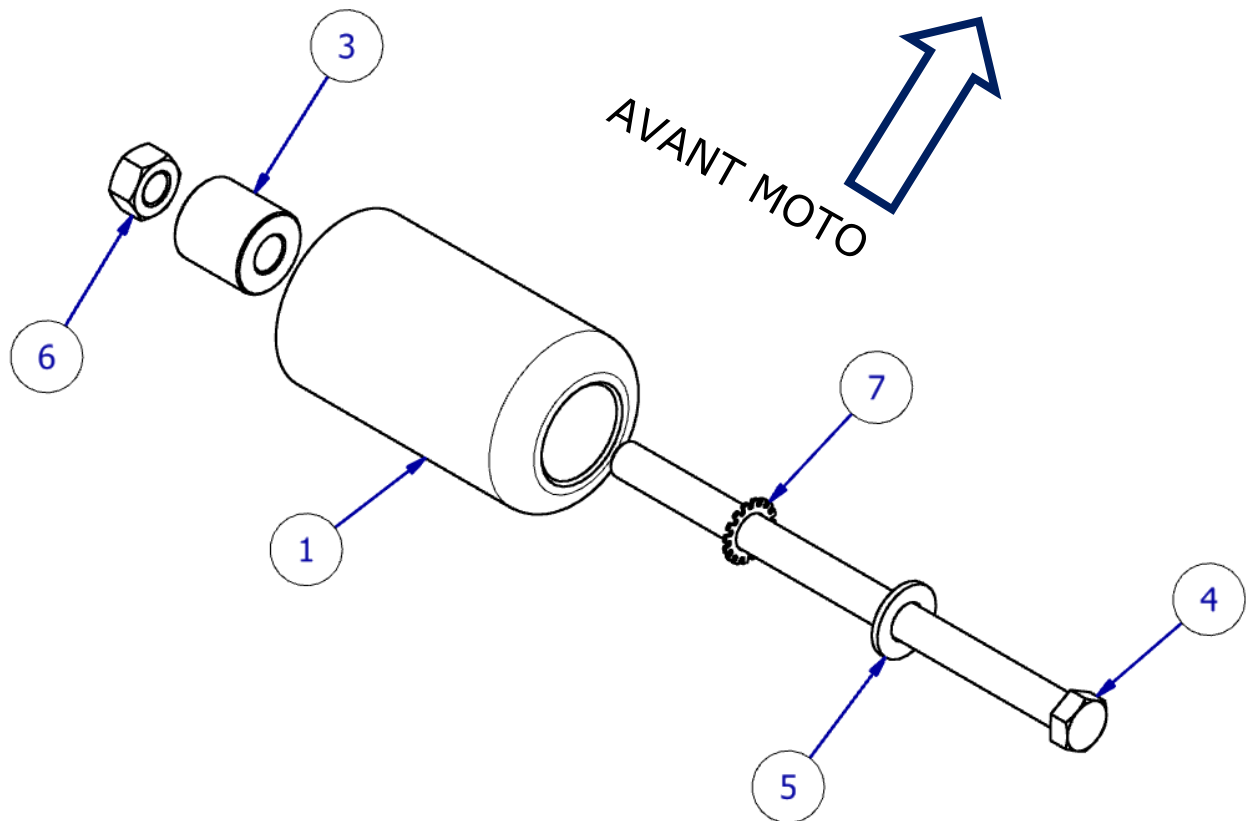

NOTICE DE MONTAGE

Côté gauche (lorsqu'on est assis sur la moto)

- **Avant d'installer les protections R&G, il est conseillé de placer un cric sous la moto à un endroit approprié pour supporter le poids du moteur pendant le montage, comme sur la photo 1. Un petit morceau de bois doit également être placé entre le cric et le point de montage pour aider à répartir la charge**
- Retirez le boulon moteur du côté gauche de la moto, voir photo 1. Vous devez tenir l'écrou arrière du boulon du moteur avec une clé de 14 mm illustrée sur la photo 2 pendant le desserrage du boulon.
- Assurez-vous que l'entretoise d'origine, indiquée par une flèche sur la photo 3, entre le moteur et le support de montage du châssis, reste en place pendant le retrait du boulon.
- Assemblez la protection crash côté gauche comme indiqué sur le schéma de montage 1 en faisant glisser une rondelle M10 (article 5) suivie d'une rondelle anti-vibration (article 7) sur le bout du boulon M10 x 1,25 x 180 mm (article 4).

R&G

Unit 1, Shelley's Lane, East Worldham, Alton, Hampshire, GU34 3AQ

Tel: +44 (0)1420 89007 Fax: +44 (0)1420 87301 www.rg-racing.com Email: info@rg-racing.com



- Ensuite, glissez une protection crash B0005 (article 1) sur le boulon, suivi de la plus petite entretoise S0727 (article 2). Votre assemblage devrait maintenant ressembler à celui de la photo 3.
- Insérez l'ensemble à la place du boulon moteur d'origine à travers le trou de montage du moteur, l'entretoise d'origine et le support de cadre, de manière à ce que les filets dépassent à travers le support de cadre, comme illustré sur la photo 4.
- Fixez un écrou M10 (article 6) sur les filets apparents à la place de l'écrou d'origine à l'aide de votre clé 14 mm et de 17 mm pour serrer l'ensemble écrou-boulon au couple recommandé. Assurez-vous que le filetage du boulon dépasse complètement à travers l'écrou en plastique et que la bobine ne puisse pas tourner.

Côté droit (lorsqu'on est assis sur la moto)

- En vous déplaçant du côté droit de la moto, répétez les étapes précédentes en assemblant la protection crash en utilisant de la plus longue entretoise S0326 (article 3) comme sur le schéma de montage 2.
- Vérifiez que les deux côtés soient bien fixés et que les protections crash ne puissent pas pivoter librement avant de prendre la route.
- Vérifiez le serrage de chaque côté régulièrement.

ISSUE 1 09/08/2019 (DM)

CONSUMER NOTICE

The catalogue description and any exhibition of samples are only broad indications of the Products and R&G may make design changes which do not diminish their performance or visual appeal and supplying them in such state shall conform to the order. The Buyer acknowledges no representation or warranty (other than as to title) has been given or will apply to the Products other than those in R&G's order or confirmation and the Buyer confirms it has chosen the Products as being of merchantable quality and suitable for its particular purposes. Where R&G fits the Products or undertakes other services it shall exercise reasonable skill and care and rectify any fault free of charge unless the workmanship has been disturbed. The Buyer is responsible for ensuring that the warranty on the motorcycle is not affected by the fitting of the Products. On return of any defective Products R&G shall at its option either supply a replacement or refund the purchase money but shall not be liable if the Products have been modified or used or maintained otherwise than in accordance with R&G's or manufacturer's instructions and good engineering practice or if the defect arises from accident or neglect. Other than identified above and subject to R&G not limiting its liability for causing death and personal injury, it shall not be liable for indirect or consequential loss and otherwise its liability shall be limited to the amounts paid by the Buyer for the Products or the fitting or service concerned. These terms do not affect the Buyer's statutory rights.

R&G RACING RETURNS POLICY (NON-FAULTY GOODS)

Returns must be pre-authorized (if not pre-authorized the return will be rejected). Goods may only be returned direct to us if they were purchased direct from us (customer must prove if necessary). Otherwise to be returned to original vendor. Goods must be in re-sellable condition, in the opinion of R&G Racing. All returns are subject to a 25% restocking and handling fee (25% of the gross value exc. P&P – at the prevailing price at time of purchase). The customer must pay any and all carriage charges. No returns of discontinued products, unless within 14 days of purchase. This policy does not affect your statutory rights and does not refer to faulty goods.

R&G

Unit 1, Shelley's Lane, East Worldham, Alton, Hampshire, GU34 3AQ

Tel: +44 (0)1420 89007 Fax: +44 (0)1420 87301 www.rg-racing.com Email: info@rg-racing.com



MONTAGEANLEITUNG FÜR CP0468 STURZPADS (RUND)
HONDA CB400SF 2008-

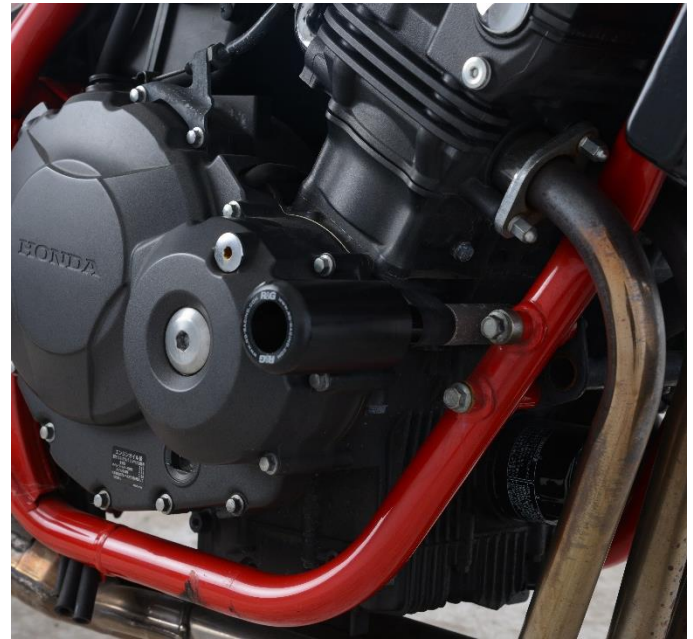
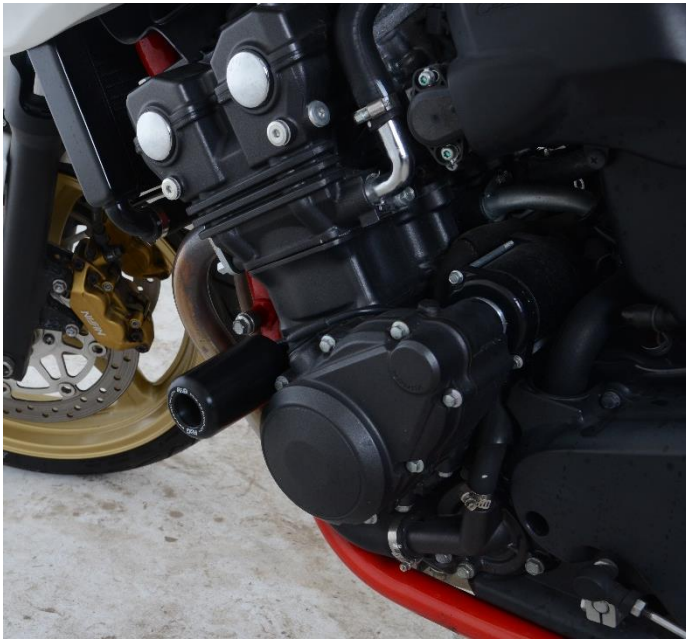

ALLE KIT-TEILE SIND UNTEN ABGEBILDET UND GEKENNZEICHNET IN DEN NACHSTEHENDEN ANWEISUNGEN

DIE ABGEBILDETEN TEILE DIENEN LEDIGLICH ZUR ERKLÄRUNG

HINWEIS: DIE VERPACKUNG DER TEILE STELLT NICHT DIE REIHENFOLGE DER MONTAGE DAR.

HINWEIS FÜR KITS MIT PLASTIKUNTERLEGSCHLEIBEN AN DEN SCHRAUBEN – *DIESE PLASTIKUNTERLEGSCHLEIBEN WERDEN NICHT FÜR DEN EINBAU BENÖTIGT!*

ÜBERPRÜFEN SIE, DASS ALLE TEILE VORHANDEN SIND, BEVOR SIE MIT DER MONTAGE BEGINNEN.

BITTE KONTAKTIEREN SIE EINEN UNSERER HÄNDLER ODER LASSEN SIE DAS KIT VON EINEM QUALIFIZIERTEN TECHNIKER MONTIEREN, WENN SIE UNSICHER SIND BEI DER MONTAGE UNSERER PRODUKTE.

EINE DIGITALE VERSION DIESER MONTAGEANLEITUNG KANN AUF FOLGENDER SEITE HERUNTERGELADEN WERDEN: WWW.RG-RACING.COM

R&G

Unit 1, Shelley's Lane, East Worldham, Alton, Hampshire, GU34 3AQ

Tel: +44 (0)1420 89007 Fax: +44 (0)1420 87301 www.rg-racing.com Email: info@rg-racing.com



SIE BENÖTIGEN FOLGENDES WERKZEUG	ALLGEM. ANZUGSDREHMOMENT
<ul style="list-style-type: none"> • STECKSCHLÜSSELSATZ INKL. 14mm und 17mm STECKSCHLÜSSEL • 14mm SCHRAUBENSCHLÜSSEL 	M4 SCHRAUBE = 8Nm M5 SCHRAUBE = 12Nm M6 SCHRAUBE = 15Nm M8 SCHRAUBE = 20Nm M10 SCHRAUBE = 40Nm M12 SCHRAUBE = 40Nm

LIEFERUMFANG

ARTIKEL-NR.	BESCHREIBUNG	MENGE
ARTIKEL 1	B0005 10MM STURZPAD	2
ARTIKEL 2	S0727 DISTANZHALTER (5mm)	1
ARTIKEL 3	S0326 DISTANZHALTER (23mm)	1
ARTIKEL 4	M10 x 1.25 x 180mm SECHSKANTSCHRAUBE	2
ARTIKEL 5	M10 x 19MM UNTERLEGSCHIEBE	2
ARTIKEL 6	M10 SELBSTSICHERNDE MUTTER	2
ARTIKEL 7	ZAHNSCHREIBE	2

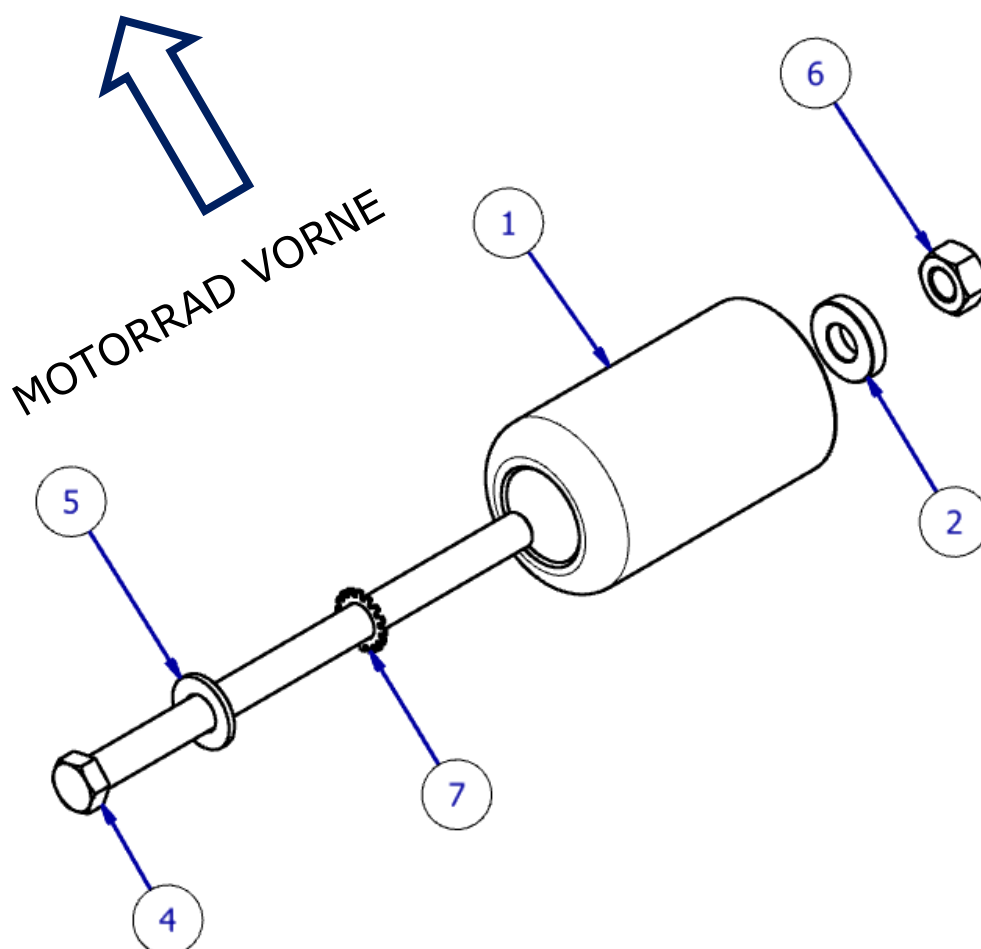

ZUSAMMENBAU ZEICHNUNG 1 – LINKE SEITE

R&G

Unit 1, Shelley's Lane, East Worldham, Alton, Hampshire, GU34 3AQ

Tel: +44 (0)1420 89007 Fax: +44 (0)1420 87301 www.rg-racing.com Email: info@rg-racing.com

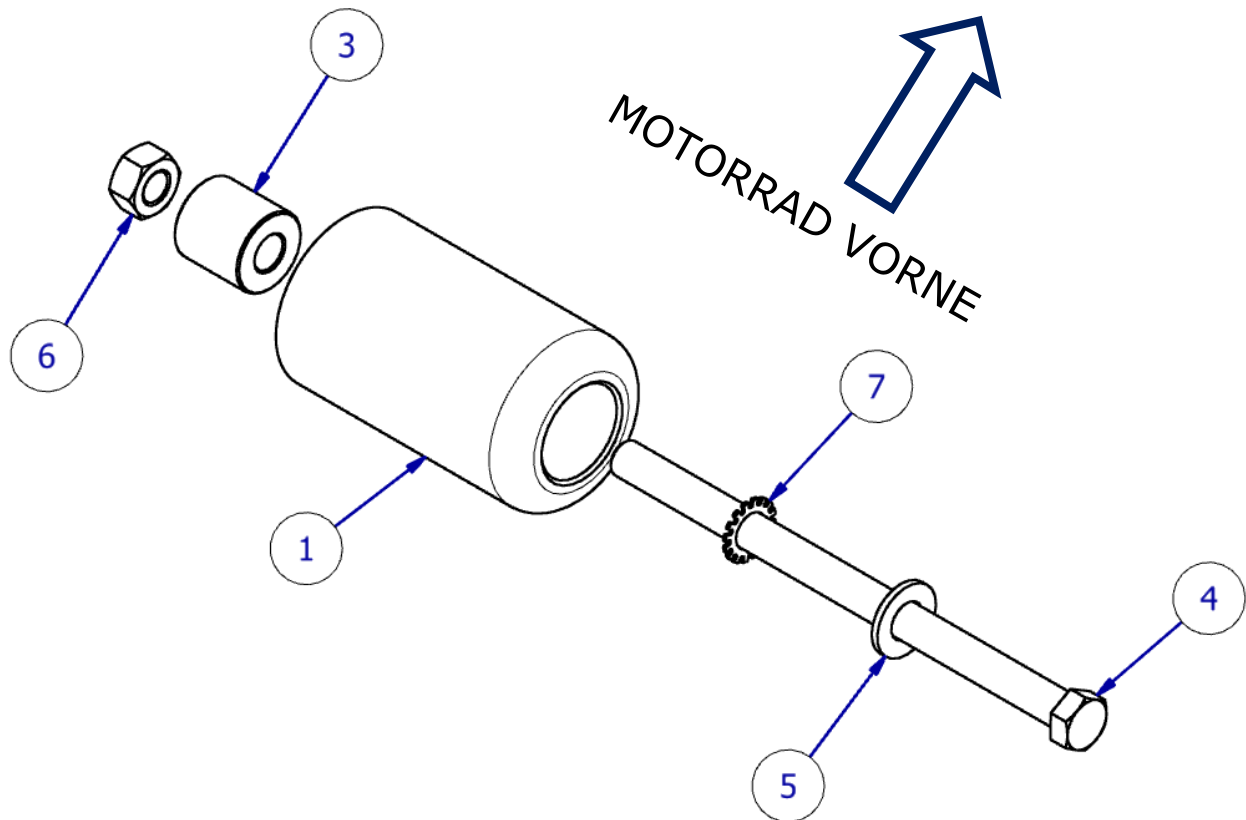

ZUSAMMENBAU ZEICHNUNG 2 – RECHTE SEITE

MONTAGEANLEITUNG

Linke Seite (in Fahrtrichtung)

- **Bevor Sie die R&G Sturzpads montieren, empfehlen wir, einen Scherenheber an einem geeigneten Montagepunkt unter das Motorrad zu stellen, um somit das Gewicht des Motors während der Montage zu stützen. Ein kleines Stück Holz sollte auch zwischen Montagepunkt und Heber platziert werden, um die Last zu verteilen. Entfernen Sie nicht mehr als eine Motorschraube gleichzeitig während der Montage, um zu verhindern, dass der Motor sich bewegt.**
- Entfernen Sie die original Montageschraube für den Motor an der linken Seite des Motorrades wie in **Abbildung 1** abgebildet. Die hintere Mutter an der Motorschraube muss mit einem 14mm Schraubenschlüssel festgehalten werden, wie in **Abbildung 2** abgebildet, während Sie die Schraube lösen.
- Stellen Sie sicher, dass der original Distanzhalter, der in **Abbildung 3** markiert ist, zwischen dem Motor und der Rahmen-Montagehalterung in Position bleibt während der Entfernung der Schraube.

R&G

Unit 1, Shelley's Lane, East Worldham, Alton, Hampshire, GU34 3AQ

Tel: +44 (0)1420 89007 Fax: +44 (0)1420 87301 www.rg-racing.com Email: info@rg-racing.com



- Das Sturzpad für die linke Seite zusammenbauen wie in **Zusammenbau Zeichnung 1** dargestellt, indem Sie eine M10 Unterlegscheibe (Artikel 5) gefolgt von einer Zahnscheibe (Artikel 7) über das Ende einer M10 x 1,25 x 180mm Schraube (Artikel 4) schieben
- Als nächstes ein B0005 Sturzpad (Artikel 1) gefolgt vom kleineren S0727 Distanzhalter (Artikel 2) über die Schraubeneinheit schieben. Die Baugruppe sollte nun aussehen wie in **Abbildung 3** abgebildet.
- Die Baugruppe nun anstelle der original Motorschraube durch die Montageöffnung für den Motor, den original Distanzhalter und die Rahmenhalterung führen, so dass das Gewinde durch die Rahmenhalterung hervorsteht – siehe **Abbildung 4**.
- Eine M10 selbstsichernde Mutter (Artikel 6) am hervorstehenden Gewinde anbringen, anstelle der Originalmutter (benutzen Sie den 14mm Schraubenschlüssel und 17mm Steckschlüssel, um die Mutter und Schraubeneinheit mit dem empfohlenen Anzugsdrehmoment zu befestigen). Stellen Sie sicher, dass das Schraubengewinde komplett durch die Kunststoffmutter ragt und das Sturzpad sich nicht drehen kann.

Rechte Seite (in Fahrtrichtung)

- Wechseln Sie zur rechten Seite des Motorrades und wiederholen Sie die bisherigen Schritte, um das Sturzpad mit dem längeren S0326 Distanzhalter (Artikel 3) zusammen zu bauen – siehe **Zusammenbau Zeichnung 2**
- Überprüfen Sie, dass beide Seiten sicher befestigt sind und stellen Sie sicher, dass die Sturzpads sich nicht drehen können, bevor Sie mit dem Motorrad fahren.
- Überprüfen Sie regelmäßig die Festigkeit an beiden Seiten.

AUSGABE 1 09/08/2019 (DM)

CONSUMER NOTICE

The catalogue description and any exhibition of samples are only broad indications of the Products and R&G may make design changes which do not diminish their performance or visual appeal and supplying them in such state shall conform to the order. The Buyer acknowledges no representation or warranty (other than as to title) has been given or will apply to the Products other than those in R&G's order or confirmation and the Buyer confirms it has chosen the Products as being of merchantable quality and suitable for its particular purposes. Where R&G fits the Products or undertakes other services it shall exercise reasonable skill and care and rectify any fault free of charge unless the workmanship has been disturbed. The Buyer is responsible for ensuring that the warranty on the motorcycle is not affected by the fitting of the Products. On return of any defective Products R&G shall at its option either supply a replacement or refund the purchase money but shall not be liable if the Products have been modified or used or maintained otherwise than in accordance with R&G's or manufacturer's instructions and good engineering practice or if the defect arises from accident or neglect. Other than identified above and subject to R&G not limiting its liability for causing death and personal injury, it shall not be liable for indirect or consequential loss and otherwise its liability shall be limited to the amounts paid by the Buyer for the Products or the fitting or service concerned. These terms do not affect the Buyer's statutory rights.

R&G RACING RETURNS POLICY (NON-FAULTY GOODS)

Returns must be pre-authorized (if not pre-authorized the return will be rejected). Goods may only be returned direct to us if they were purchased direct from us (customer must prove if necessary). Otherwise to be returned to original vendor. Goods must be in re-sellable condition, in the opinion of R&G Racing. All returns are subject to a 25% restocking and handling fee (25% of the gross value exc. P&P – at the prevailing price at time of purchase). The customer must pay any and all carriage charges. No returns of discontinued products, unless within 14 days of purchase. This policy does not affect your statutory rights and does not refer to faulty goods.

R&G

Unit 1, Shelley's Lane, East Worldham, Alton, Hampshire, GU34 3AQ

Tel: +44 (0)1420 89007 Fax: +44 (0)1420 87301 www.rg-racing.com Email: info@rg-racing.com